

0156-27XXL

Bornas de Conexión PCB > Bornas Macho PCB

Date:2025-08-21

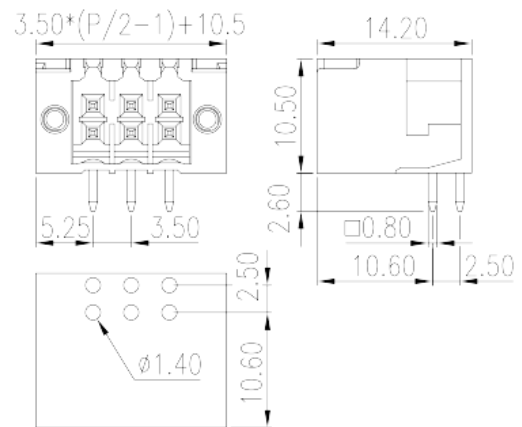

The web catalog is for reference only. Dinkle remains the right of product modification and engineering change of the design. The final product is made according to engineering drawing.

Descripción del producto

Pitch: 3.50mm, 150V, 10A

Informacion General

| | |
|---|--|
| Descripción corta | PCB Connector – Socket, Reflow Soldering |
| CategoryCategoría | PCB Connector – Socket |
| Paso(mm) | 3.5 |
| Color | Black (default) |
| Tipo de anclaje | With threaded flange |
| Metodo de soldadura | Reflow Soldering |
| Largo(mm) | $3.50 \times (P/2 - 1) + 10.5$ |
| Ancho(mm) | 14.2 |
| Alto (mm) | 10.5 |
| Dimensiones del pin (Espesor x anchura) | 0.8x0.8 |
| Diametro de taladro en PCB | 1.4 |
| Numero de posiciones | 04P~40P |
| Nivel | Double level |

Informacion materia prima

| | |
|----------|---------------------------|
| Aislante | HIGH-TEMPERATURE PLASTICS |
|----------|---------------------------|

| | |
|---|-------------------|
| Grupo de aislante | IIIa |
| Máximo retardo llama, de acuerdo con UL94 | V0 |
| Resistencia de aislamiento | □500MΩ at DC 500V |
| Conductor | COPPER ALLOY |
| Acabado | Tin PLATED |
| | 1 |

Datos IEC

| | |
|------------------------------------|-----|
| Máximo voltaje(V) | 320 |
| Máxima corriente (A) | 10 |
| Máximo voltaje (II/2)(V) | 320 |
| Máximo voltaje (III/2)(V) | 160 |
| Máximo voltaje (III/3)(V) | 160 |
| Máximo voltaje de pico (II/2)(KV) | 2.5 |
| Máximo voltaje de pico (III/2)(KV) | 2.5 |
| Máximo voltaje de pico (III/3)(KV) | 2.5 |
| Apriete con pestaña max. (N.m) | 0.2 |

Datos UL

| | |
|------------------------------------|-----|
| Máximo voltaje (UL/CUL Group B)(V) | 150 |
| Máximo voltaje (UL/CUL Group B)(A) | 10 |

Medio ambiente & Seguridad

| | |
|------------------------------------|-----|
| Protección táctil (si o No) | YES |
| Máxima temperatura de trabajo (°C) | 120 |
| Mínima temperatura de trabajo (°C) | -40 |

Homologación UL

| | |
|-------------------------------|-----|
| Máximo voltaje (Group B)(V) | 150 |
| Máxima corriente (Group B)(A) | 10 |

Homologación CUL

| | |
|-------------------------------|-----|
| Máximo voltaje (Group B)(V) | 150 |
| Máxima corriente (Group B)(A) | 10 |

Dibujo

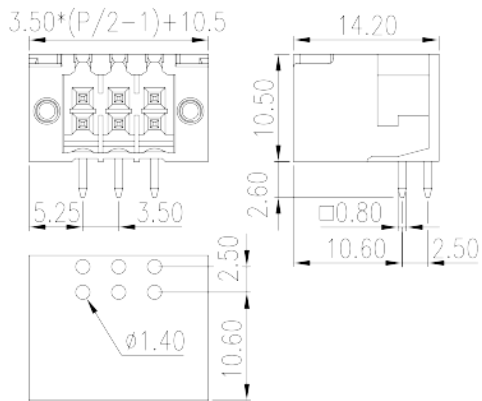

Aprobaciones

