

# W3K500-XXP

PCB > PCB

:2026-05-14 :V1

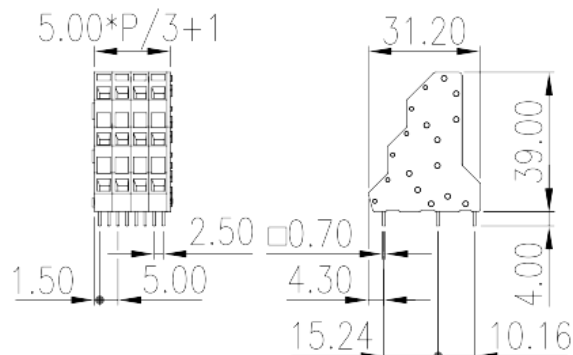

Pitch : 5.00mm, 300V, 10A

	PCB Terminal Blocks, Spring Clamp Connection
	PCB Terminal Blocks
(mm)	5.00
	Grey (default)
	Spring Clamp Connection
	Without
(mm)	$5.00 * (P/3 - 1) + 6.0$
(mm)	31.2
(mm)	39
(    x    ) (mm)	0.7x0.7
PCB (mm)	1.2
(    )	03P~72P
	Triple level
	PA
	I
UL 94	V0



	500M at DC 500V
	COPPER ALLOY
	Tin PLATED

**-IEC**

(V)	450
(A)	24
(II/2)(V)	630
(III/2)(V)	450
(III/3)(V)	320
(II/2)(KV)	4
(III/2)(KV)	4
(III/3)(KV)	4
(mm <sup>2</sup> )	0.5
(mm <sup>2</sup> )	2.5
(mm <sup>2</sup> )	0.5
(mm <sup>2</sup> )	2.5
(mm <sup>2</sup> )	0.5
(mm <sup>2</sup> )	1.5
(mm <sup>2</sup> )	0.5
(mm <sup>2</sup> )	1.5
<sup>2</sup> (mm <sup>2</sup> )	0.5
<sup>2</sup> (mm <sup>2</sup> )	1
Width)(mm) (Blade thickness x	0.6x3.5
	6~7

**-UL**

(UL/CUL Group B)(V)	300
(UL/CUL Group B)(A)	10
(UL/CUL Group C)(V)	150
(UL/CUL Group C)(A)	10



(UL/CUL Group D)(V)		300
(UL/CUL Group D)(A)		10
UL/CUL	AWG	28
UL/CUL	AWG	12
UL/CUL	AWG	28
UL/CUL	AWG	12

&amp;

가	(YES or NO)	YES
		120
		-40

**UL**

(Group B)(AWG)		28~12
(Group B)(V)		300
(Group B)(A)		10
(Group C)(AWG)		28~12
(Group C)(V)		150
(Group C)(A)		10
(Group D)(AWG)		28~12
(Group D)(V)		150
(Group D)(A)		10

**CUL**

(Group B)(AWG)		28~12
(Group B)(V)		300
(Group B)(A)		10
(Group C)(AWG)		28~12
(Group C)(V)		150
(Group C)(A)		10
(Group D)(AWG)		28~12
(Group D)(V)		150
(Group D)(A)		10

