

EK350V4L-XXP

PCB > PCB

:2026-07-04 :V1

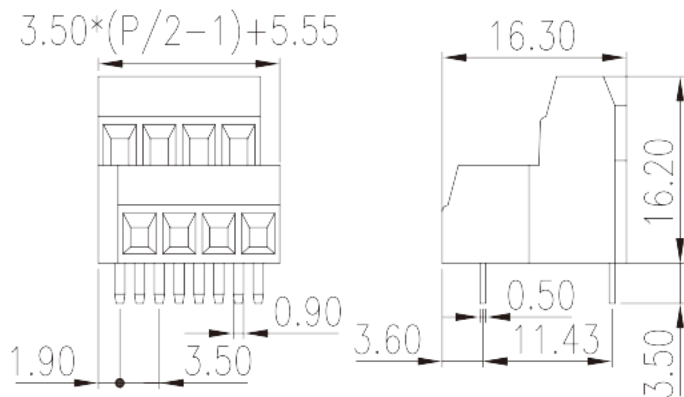

Pitch : 3.50mm, 300V, 10A

		PCB Terminal Blocks, Screw Connection
		PCB Terminal Blocks
(mm)		3.50
		Green (default)
		Screw Connection
		Without
(mm)		$3.50*(P-1)+5.55$
(mm)		16.3
(mm)		16.2
() x () (mm)		0.5x0.9
PCB (mm)		1.2~1.3
()		04P~40P
		Double level
		PA
		I
UL 94		V0



	500M at DC 500V
	COPPER ALLOY
	Tin PLATED

-IEC

(V)	160
(A)	10
(II/2)(V)	320
(III/2)(V)	160
(III/3)(V)	160
(II/2)(KV)	2.5
(III/2)(KV)	2.5
(III/3)(KV)	2.5
(mm ²)	0.2
(mm ²)	1.5
(mm ²)	0.2
(mm ²)	1.5
(mm ²) , ,	0.25
(mm ²) , ,	0.5
(mm ²) , ,	0.25
(mm ²) , ,	0.5
2 (mm ²)	0.5
2 (mm ²)	0.5
	M2
Width)(mm) (Blade thickness x	0.4x2.5
(N.m)	0.2
	5~6

-UL

(UL/CUL Group B)(V)	300
(UL/CUL Group B)(A)	10
(UL/CUL Group D)(V)	300



(UL/CUL Group D)(A)		10
UL/CUL	AWG	30
UL/CUL	AWG	16
UL/CUL	AWG	30
UL/CUL	AWG	16

&

가	(YES or NO)	YES
		120
		-40

UL

(Group B)(AWG)		30~16
(Group B)(V)		300
(Group B)(A)		10
(Group D)(AWG)		30~16
(Group D)(V)		300
(Group D)(A)		10

CUL

(Group B)(AWG)		30~16
(Group B)(V)		300
(Group B)(A)		10
(Group D)(AWG)		30~16
(Group D)(V)		300
(Group D)(A)		10

--	--	--

