

ESK150VM-XXP

PCB > PCB

:2026-07-04 :1.1

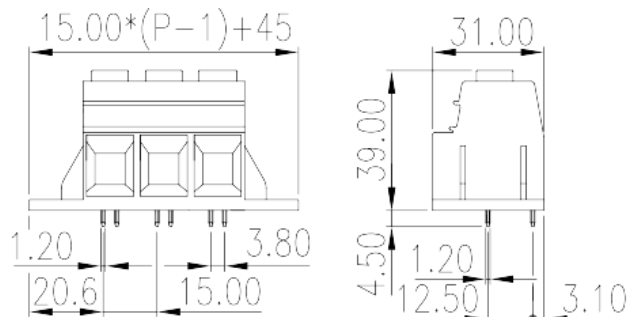

Pitch : 15.00mm, 600V, 115A (FW2)/125A (FW1)

		PCB Terminal Blocks, Screw Connection
		PCB Terminal Blocks
(mm)		15.00
		Green (default)
		Screw Connection
		Without
(mm)		$15.00*(P-1)+45.00$
(mm)		31
(mm)		39
() x () (mm)		1.2x1.2
PCB (mm)		1.7
()		02P~09P
		Single level
		PA
		I
UL 94		V0



	500M at DC 500V
	COPPER ALLOY
	Tin PLATED

-IEC

(V)	1000
(A)	125
(II/2)(V)	1000
(III/2)(V)	1000
(III/3)(V)	800
(II/2)(KV)	8
(III/2)(KV)	8
(III/3)(KV)	8
(mm ²)	0.5
(mm ²)	35
(mm ²)	0.5
(mm ²)	35
(mm ²) , ,	0.25
(mm ²) , ,	35
(mm ²) , ,	0.25
(mm ²) , ,	35
2 (mm ²)	0.5
2 (mm ²)	6
2 (mm ²)	0.5
2 (mm ²)	6
	M5
Width)(mm) (Blade thickness x	1.0x5.5
Philips	PZ2
(N.m)	3.7
(N.m)	4.5
	18~19

-UL



(UL/CUL Group B)(V)		600
(UL/CUL Group B)(A)		115(FW2),125(FW1)
(UL/CUL Group C)(V)		600
(UL/CUL Group C)(A)		115(FW2),125(FW1)
(UL/CUL Group D)(V)		600
(UL/CUL Group D)(A)		5
UL/CUL	AWG	2
UL/CUL	AWG	20
UL/CUL	AWG	2
UL/CUL	AWG	20

&

가	(YES or NO)	YES
		120
		-40

UL

(Group B)(AWG)		20~2
(Group B)(V)		600
(Group B)(A)		115(FW2),125(FW1)
(Group C)(AWG)		20~2
(Group C)(V)		600
(Group C)(A)		115(FW2),125(FW1)
(Group D)(AWG)		20~2
(Group D)(V)		600
(Group D)(A)		5

CUL

(Group B)(AWG)		20~2
(Group B)(V)		600
(Group B)(A)		115(FW2),125(FW1)
(Group C)(AWG)		20~2
(Group C)(V)		600
(Group C)(A)		115(FW2),125(FW1)

(Group D)(AWG)	20~2
(Group D)(V)	600
(Group D)(A)	5

VDE

(mm ²)	0.5~35
(V)	1000
(A)	125

