

EPK116VN-XXP

PCB > PCB

:2026-07-05 :V1

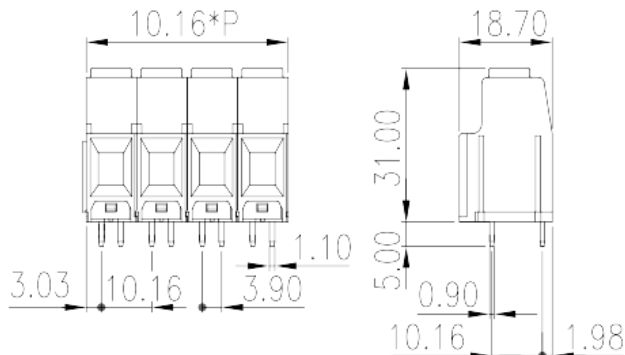
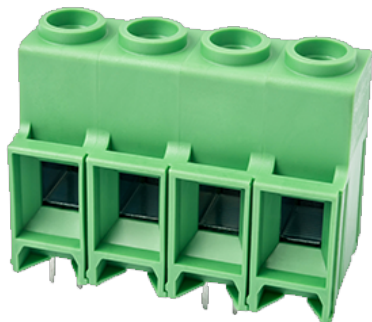

Pitch : 10.16mm, 600V, 57sol/65str

	PCB Terminal Blocks, Screw Connection
	PCB Terminal Blocks
(mm)	10.16
	Green (default)
	Screw Connection
	Without
(mm)	10.16*P
(mm)	18.7
(mm)	31
(x) (mm)	0.9x1.1
PCB (mm)	1.5
()	02P~16P
	Single level
	PA
	I
UL 94	V0



	500M at DC 500V
	COPPER ALLOY
	Tin PLATED

-IEC

(V)	1000
(A)	76
(II/2)(V)	1000
(III/2)(V)	1000
(III/3)(V)	800
(II/2)(KV)	8
(III/2)(KV)	8
(III/3)(KV)	8
(mm ²)	0.5
(mm ²)	16
(mm ²)	0.5
(mm ²)	16
(mm ²)	0.25
(mm ²)	10
(mm ²)	0.25
(mm ²)	10
2 (mm ²)	0.5
2 (mm ²)	4
2 (mm ²)	0.5
2 (mm ²)	4
	M4
Width)(mm) (Blade thickness x	0.8x4.0
(N.m)	1.2
	12

-UL

(UL/CUL Group B)(V)	600
---------------------	-----



(UL/CUL Group B)(A)		57sol / 65str
(UL/CUL Group C)(V)		600
(UL/CUL Group C)(A)		57sol / 65str
UL/CUL	AWG	20
UL/CUL	AWG	6
UL/CUL	AWG	20
UL/CUL	AWG	6

&

가	(YES or NO)	YES
		120
		-40

UL

(Group B)(AWG)		20~6
(Group B)(V)		600
(Group B)(A)		57sol / 65str
(Group C)(AWG)		20~6
(Group C)(V)		600
(Group C)(A)		57sol / 65str

CUL

(Group B)(AWG)		20~6
(Group B)(V)		600
(Group B)(A)		57sol / 65str
(Group C)(AWG)		20~6
(Group C)(V)		600
(Group C)(A)		57sol / 65str

VDE

(mm ²)		0.5~16
(V)		1000
(A)		76

