

AK2.5-PE

DIN

>

:2026-07-04

:1.1

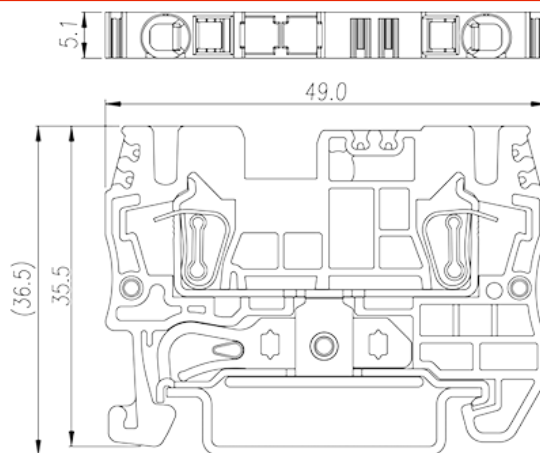
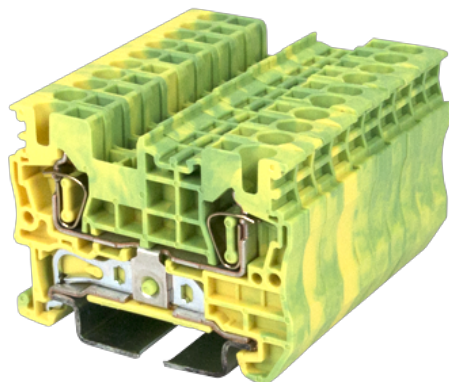

Green-Yellow (default)

	DIN Rail terminal blocks, Grounding terminal blocks
	Grounding terminal blocks
	Green-Yellow (default)
	Spring Clamp Connection
	Rail Mounting
(mm)	49
(mm)	5.1
(mm)	35.5
	Single level
	2
	PA
	I
UL 94	V0
	500M at DC 500V

-IEC



(III/3)(KV)	8
(mm ²)	0.2
(mm ²)	4
(mm ²)	0.2
(mm ²)	2.5
(mm ²) , ,	0.25
(mm ²) , ,	1.5
(mm ²) , ,	0.25
(mm ²) , ,	1.5
Width)(mm) (Blade thickness x	0.6x3.5
	10
	TS-35
	YES
	YES

-UL

UL/CUL	AWG	30
UL/CUL	AWG	12
UL/CUL	AWG	30
UL/CUL	AWG	12

&

(YES or NO)	YES
가 (YES or NO)	YES
	120
	-40

UL

(Group B)(AWG)	30~12
(Group C)(AWG)	30~12

CUL

--	--

(Group B)(AWG)	30~12
----------------	-------

VDE

(mm ²)	0.2~2.5
--------------------	---------

