

0159-31XX

PCB > PCB -

:2026-07-05 :V1

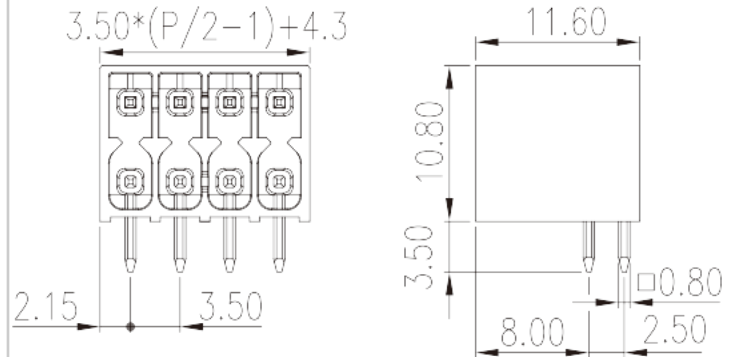

Pitch : 3.50 mm, 150V, 8A

	PCB Connector – Socket, Wave soldering
	PCB Connector – Socket
(mm)	3.50
	Black (default)
	Without
	Wave soldering
(mm)	$3.50 * (P/2 - 1) + 4.3$
(mm)	11.6
(mm)	10.8
(x) (mm)	0.8x0.8
PCB (mm)	1.4
()	04P~40P
	Double level
	PA
	I
UL 94	V0



	500M at DC 500V
	COPPER ALLOY
	Tin PLATED

-IEC

(V)	250
(A)	8
(II/2)(V)	250
(III/2)(V)	160
(III/3)(V)	160
(II/2)(KV)	2.5
(III/2)(KV)	2.5
(III/3)(KV)	2.5

-UL

(UL/CUL Group B)(V)	300
(UL/CUL Group B)(A)	8

&

가 (YES or NO)	YES
	120
	-40

UL

(Group B)(V)	150
(Group B)(A)	8
(Group C)(V)	50
(Group C)(A)	8
(Group D)(V)	300
(Group D)(A)	8

CUL

(Group B)(V)	150
(Group B)(A)	8
(Group C)(V)	50

(Group C)(A)	8
(Group D)(V)	300
(Group D)(A)	8

