

0221-41XXL

PCB > PCB -

:2026-07-05 :V1

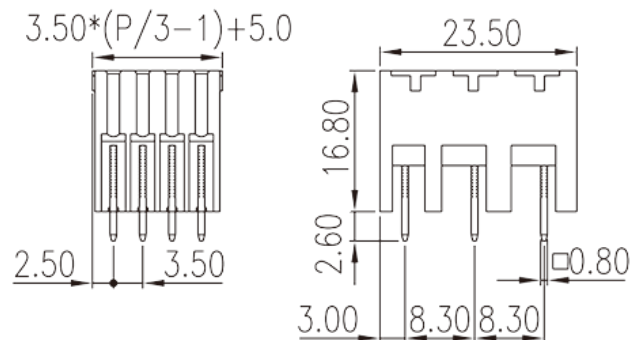

Pitch : 3.50 mm, 300V, 8A

	PCB Connector – Socket, Reflow soldering
	PCB Connector – Socket
(mm)	3.50
	Black (default)
	Without
	Reflow Soldering (Temperature condition according to standard IPC/JEDEC J-STD-020E)
(mm)	$3.50 * (P/3-1) + 5.0$
(mm)	23.5
(mm)	16.8
(x) (mm)	0.8x0.8
PCB (mm)	1.3~1.4
()	06P~72P
	Triple level
	HIGH-TEMPERATURE PLASTICS
	I



UL 94	V0
	500M at DC 500V
	COPPER ALLOY
	Tin PLATED
MSL	2

-IEC

(V)	320
(A)	8
(II/2)(V)	320
(III/2)(V)	200
(III/3)(V)	200
(II/2)(KV)	2.5
(III/2)(KV)	2.5
(III/3)(KV)	2.5

-UL

(UL/CUL Group B)(V)	300
(UL/CUL Group B)(A)	8

&

가 (YES or NO)	YES
	120
	-40

--	--

