

DKK4N

DIN

>

:2026-07-04

:1.2

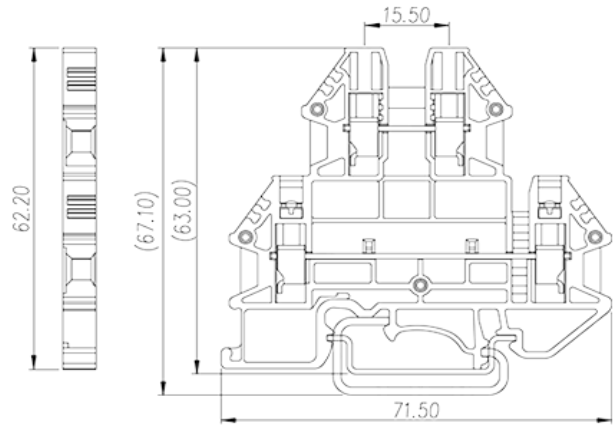
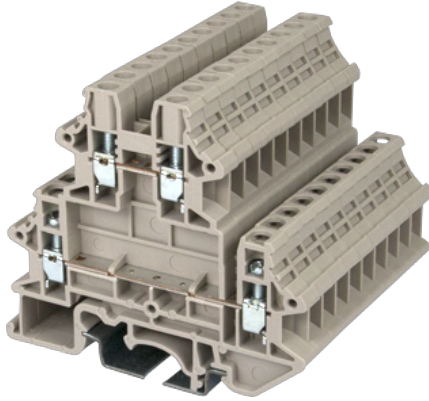

M3, 600V, 30A, Beige (default)

	DIN rail terminal blocks, Bi level feed through terminal blocks
	Bi level feed through terminal blocks
	Beige (default)
	Screw connection
	Rail mounting
(mm)	71.5
(mm)	6.1
(mm)	62.2
()	1P
	Double level
	4
	PA
	I
UL 94	V0
	500M at DC 500V

-IEC

(V)		800
(A)		32
(III/3)(V)		800
(II/2)(KV)		8
(III/2)(KV)		8
(III/3)(KV)		8
(mm ²)		0.34
(mm ²)		6
(mm ²)		0.34
(mm ²)		4
(mm ²)	,	0.34
(mm ²)	,	4
(mm ²)	,	0.34
(mm ²)	,	4
2	(mm ²)	0.34
2	(mm ²)	2.5
2	(mm ²)	0.34
2	(mm ²)	2.5
(mm ²) 2	,	0.34
(mm ²) 2	,	1.5
2	(mm ²)	0.5
2	(mm ²)	2.5
		M3
Width)(mm)	(Blade thickness x	0.6x3.5
Philips		PH0
(N.m)		0.5
(N.m)		0.5
(N.m)		0.6
		9~11

	TS-35
	YES
	NO

-UL

(UL/CUL Group B)(V)		600
(UL/CUL Group B)(A)		30
(UL/CUL Group C)(V)		600
(UL/CUL Group C)(A)		30
UL/CUL	AWG	22
UL/CUL	AWG	10
UL/CUL	AWG	22
UL/CUL	AWG	10

&

(YES or NO)		YES
가 (YES or NO)		YES
		120
		-40

UL

(Group B)(AWG)		22~10
(Group B)(V)		600
(Group B)(A)		30
(Group C)(AWG)		22~10
(Group C)(V)		600
(Group C)(A)		30

VDE

(mm ²)		0.34~4
(V)		800
(A)		32

