

DK16N-PE

DIN

>

:2026-07-04

:1.2

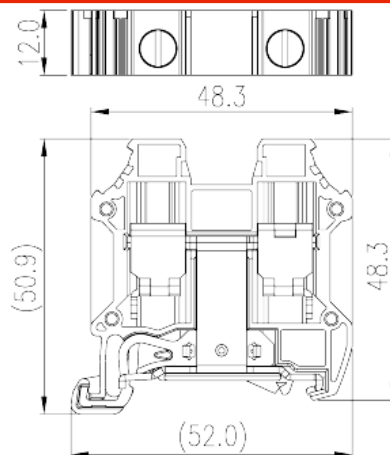
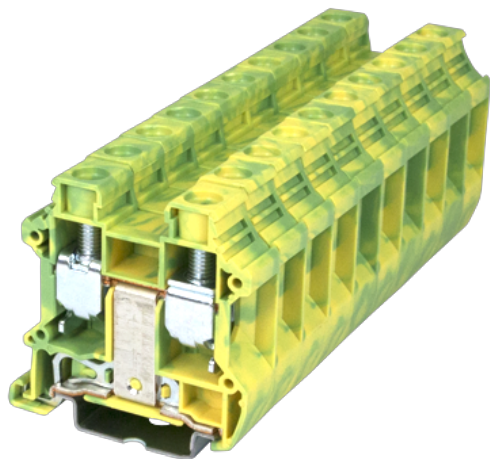

M5, Green-Yellow (default)

	Grounding Terminal Block, Screw Connection
	Grounding Terminal Block
	Green-Yellow (default)
	Screw connection
	Rail mounting
(mm)	52
(mm)	12
(mm)	50.9
()	1P
	Single level
	2
	PA
	I
UL 94	V0
	500M at DC 500V

-IEC

(V)	1000
(III/3)(V)	1000
(III/3)(KV)	8
(mm ²)	1.5
(mm ²)	25
(mm ²)	1.5
(mm ²)	16
(mm ²) , ,	1.5
(mm ²) , ,	16
(mm ²) , ,	1.5
(mm ²) , ,	16
2 (mm ²)	1.5
2 (mm ²)	6
2 (mm ²)	1.5
2 (mm ²)	6
(mm ²) ² , ,	1.5
(mm ²) ² , ,	6
² (mm ²) , ,	1.5
² (mm ²) , ,	10
	M5
Width)(mm) (Blade thickness x	0.8x4.0
(N.m)	2.5
	12~14
	TS-35、TS-35/15
	YES
	YES

-UL

(UL/CUL Group B)(V)	600
---------------------	-----

(UL/CUL Group C)(V)		600
UL/CUL	AWG	14
UL/CUL	AWG	3
UL/CUL	AWG	14
UL/CUL	AWG	3

&

(YES or NO)		YES
가 (YES or NO)		YES
		120
		-40

VDE

(mm ²)		1.5~16
--------------------	--	--------

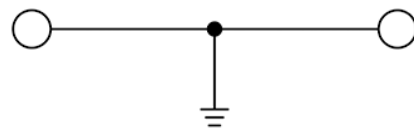
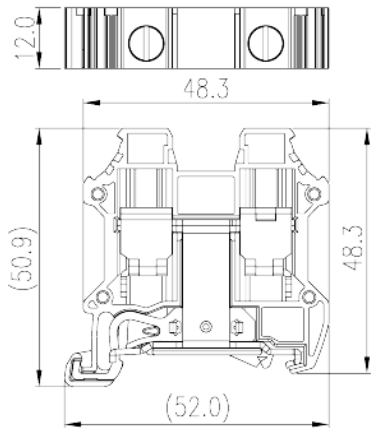

circuit diagram

