

DP1.5N-TN

DIN

>

:2026-07-04

:1.1

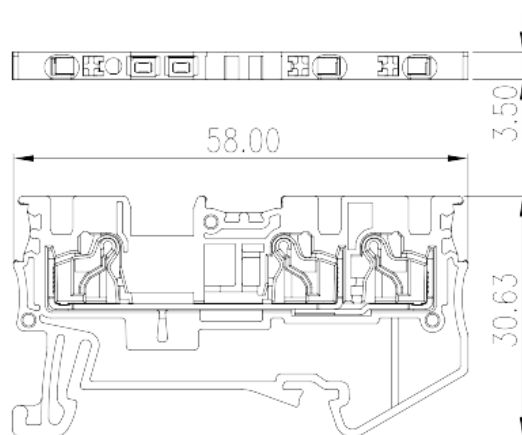
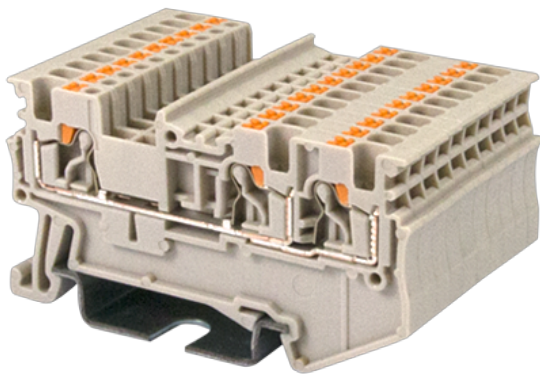

300V, 15A, Beige (default)

	Single level Feed-Through Terminal Block, Push-in Design
	Single level Feed Through Terminal Block
	Beige (default)
	Push-in Design
	Rail Mounting
(mm)	58
(mm)	3.5
(mm)	30.6
()	1P
	Single level
	3
	PA
	I
UL 94	V0
	500M at DC 500V

-IEC

(V)	500
(A)	17.5
(III/3)(V)	500
(III/3)(KV)	6
(mm ²)	0.14
(mm ²)	1.5
(mm ²)	0.14
(mm ²)	1.5
(mm ²) , ,	0.25
(mm ²) , ,	1.5
(mm ²) , ,	0.25
(mm ²) , ,	0.75
Width)(mm) (Blade thickness x	0.4x2.5
	8
	TS-35
	YES
	NO

-UL

(UL/CUL Group B)(V)	300
(UL/CUL Group B)(A)	15
(UL/CUL Group C)(V)	300
(UL/CUL Group C)(A)	15
(UL/CUL Group D)(V)	300
(UL/CUL Group D)(A)	10
UL/CUL AWG	26
UL/CUL AWG	14
UL/CUL AWG	26
UL/CUL AWG	14

&



(YES or NO)	YES
가 (YES or NO)	YES
	120
	-40

UL

(Group B)(AWG)	26~14
(Group B)(V)	300
(Group B)(A)	15
(Group C)(AWG)	26~14
(Group C)(V)	300
(Group C)(A)	15
(Group D)(AWG)	26~14
(Group D)(V)	300
(Group D)(A)	10

CUL

(Group B)(AWG)	26~14
(Group B)(V)	300
(Group B)(A)	15
(Group C)(AWG)	26~14
(Group C)(V)	300
(Group C)(A)	15
(Group D)(AWG)	26~14
(Group D)(V)	300
(Group D)(A)	10

VDE

(mm ²)	0.14~1.5
(V)	500
(A)	17.5

