

DP6N-TR-PE

DIN

>

:2026-07-04

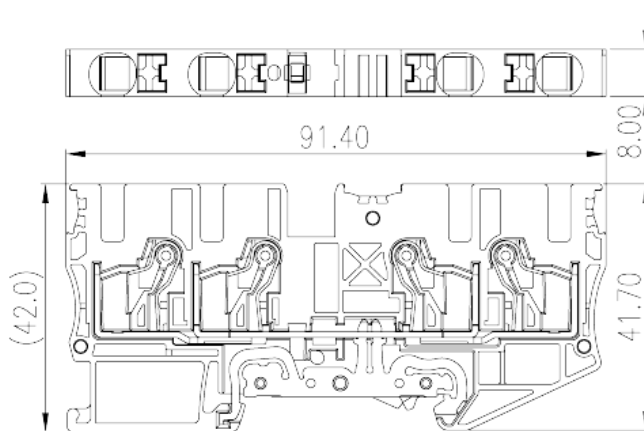
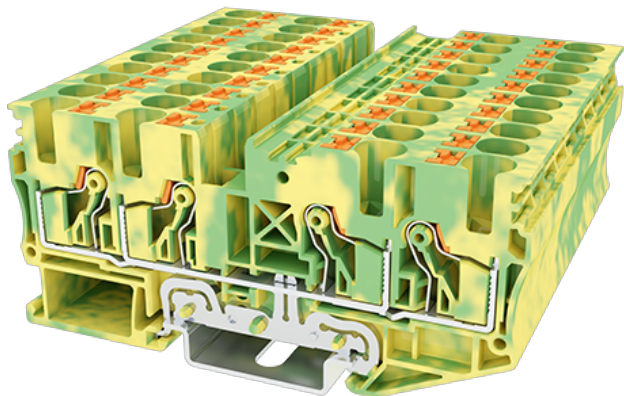

600V, Green-Yellow (default)

	Grounding Terminal Block, Push-in Design
	Grounding Terminal Block
	Green-Yellow (default)
	Push-in Design
	Rail mounting
(mm)	91.4
(mm)	8
(mm)	42
()	1P
	Single level
	4
	PA
	I
UL 94	V0
	500M at DC 500V

-IEC

(V)		1000
(III/3)(V)		1000
(III/3)(KV)		8
(mm ²)		0.5
(mm ²)		10
(mm ²)		0.5
(mm ²)		6
(mm ²)	,	0.5
(mm ²)	,	6
(mm ²)	,	0.5
(mm ²)	,	6
² (mm ²)	,	0.5
² (mm ²)	,	1.5
Width)(mm)	(Blade thickness x	0.8x4.0
		12
		TS-35、TS-35/15
		YES
		YES

-UL

(UL/CUL Group B)(V)		600
(UL/CUL Group C)(V)		600
UL/CUL	AWG	20
UL/CUL	AWG	8
UL/CUL	AWG	20
UL/CUL	AWG	8

&

(YES or NO)		YES
가 (YES or NO)		YES

	120
	-40

UL

(Group B)(AWG)	20~8
(Group B)(V)	600
(Group C)(AWG)	20~8
(Group C)(V)	600

CUL

(Group B)(AWG)	20~8
(Group B)(V)	600
(Group C)(AWG)	20~8
(Group C)(V)	600

