

2EHDRM-XXPWR

PCB >

:2026-07-05 :V1

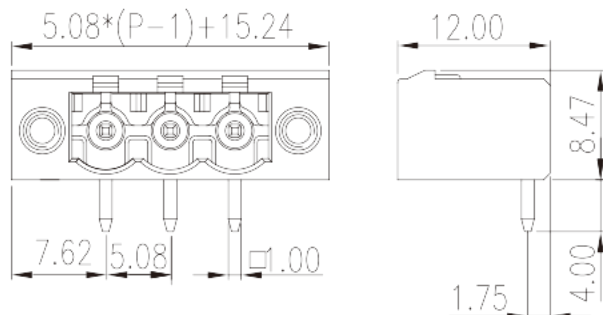

Pitch : 5.08 mm, 300V, 20A

| | |
|------------------|--|
| | PCB Connector – Socket, Wave soldering |
| | PCB Connector – Socket |
| (mm) | 5.08 |
| | Black (default) |
| | With threaded flange |
| | Wave Soldering |
| (mm) | $5.08 \times (P-1) + 15.24$ |
| (mm) | 12 |
| (mm) | 8.47 |
| (x) (mm) | 1.0x1.0 |
| PCB (mm) | 1.6~1.7 |
| () | 02P~24P |
| | Single level |
| | PA |
| | I |
| UL 94 | V0 |



500M at DC 500V

COPPER ALLOY

Tin PLATED

-IEC

| | |
|-------------|-----|
| (V) | 630 |
| (A) | 18 |
| (II/2)(V) | 630 |
| (III/2)(V) | 320 |
| (III/3)(V) | 320 |
| (II/2)(KV) | 4 |
| (III/2)(KV) | 4 |
| (III/3)(KV) | 4 |
| (N.m) | 0.3 |

-UL

| | |
|---------------------|-----|
| (UL/CUL Group B)(V) | 300 |
| (UL/CUL Group B)(A) | 20 |
| (UL/CUL Group D)(V) | 300 |
| (UL/CUL Group D)(A) | 10 |

UL

| | |
|--------------|-----|
| (Group B)(V) | 300 |
| (Group B)(A) | 20 |
| (Group D)(V) | 300 |
| (Group D)(A) | 10 |

CUL

| | |
|--------------|-----|
| (Group B)(V) | 300 |
| (Group B)(A) | 20 |
| (Group D)(V) | 300 |
| (Group D)(A) | 10 |

