

DKUP60-XXPK

NEMA

>

:2026-07-05

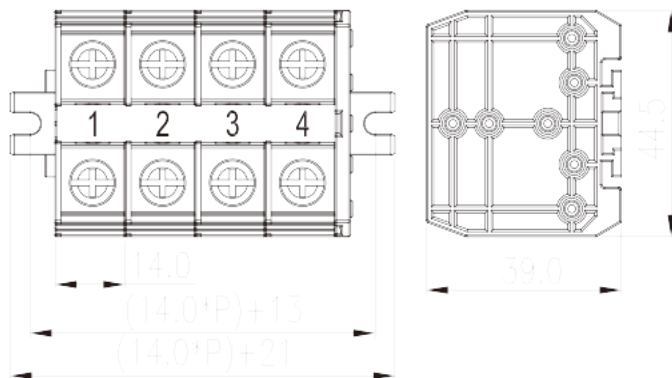

M5, 600V, 60/90A

	Panel Mounting, Screw Connection
	Panel Mounting
(mm)	14
	Refer to drawing
	Screw Connection
	Panel Mounting
(mm)	14.00*P+21
(mm)	44.5
(mm)	39
	01P~16P
()	01P~16P
	1
	2~32
	PC
	a
UL 94	V2



	1000M at DC 500V
	COPPER ALLOY
	Tin PLATED

-IEC

(V)	800
(A)	76
(III/3)(V)	800
(III/3)(KV)	8
(mm ²)	0.5
(mm ²)	16
(mm ²)	0.5
(mm ²)	16
	M5
Philips	PH2
(N.m)	2.6~3.7
(N.m)	2.6
(N.m)	3.7
	The stripping length depends on the specification provided by the cablelug manufacturer.
	TS-35N、TS-35/15N
	YES
	NO

-UL

(UL/CUL Group B)(V)	600
(UL/CUL Group B)(A)	60
(UL/CUL Group C)(V)	600
(UL/CUL Group C)(A)	60
(UL/CUL Group D)(V)	600
(UL/CUL Group D)(A)	60
UL/CUL AWG	20
UL/CUL AWG	6
UL/CUL AWG	20
UL/CUL AWG	6

&

(YES or NO)	YES
가 (YES or NO)	NO
	125
	-40

UL

(Group B)(AWG)	20-6/(2)20-(2)8
(Group B)(V)	600
(Group B)(A)	60/90
(Group C)(AWG)	20-6/(2)20-(2)8
(Group C)(V)	600
(Group C)(A)	60/90
(Group D)(AWG)	20-6/(2)20-(2)8
(Group D)(V)	600
(Group D)(A)	5

CUL

(Group B)(AWG)	20-6/(2)20-(2)8
(Group B)(V)	600
(Group B)(A)	60/90
(Group C)(AWG)	20-6/(2)20-(2)8
(Group C)(V)	600
(Group C)(A)	60/90
(Group D)(AWG)	20-6/(2)20-(2)8
(Group D)(V)	600
(Group D)(A)	5

VDE

(mm ²)	0.5~16
(V)	800
(A)	76

