

DKK2.5N-PE

DIN

>

:2026-07-04

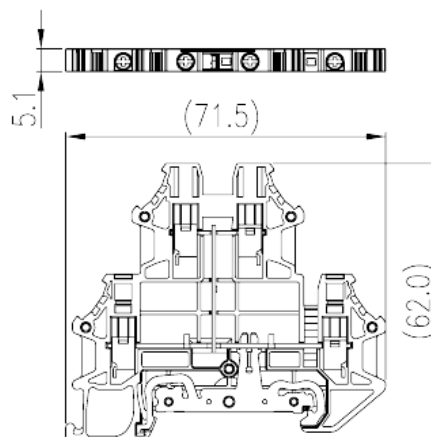
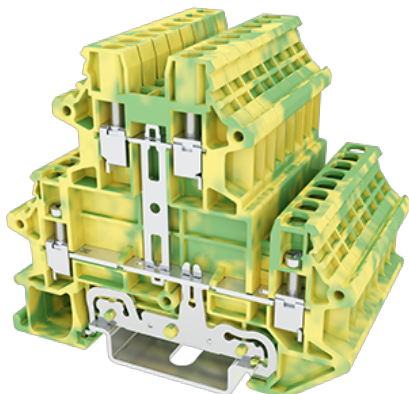

M2.5, 600V, Green-Yellow (default)

	DIN rail terminal blocks, Bi level feed, Grounding terminal blocks
	Grounding Terminal Block
	Green-Yellow (default)
	Screw connection
	Rail mounting
(mm)	71.5
(mm)	5.1
(mm)	62
()	1P
	Double level
	4
	PA
	I
UL 94	V0
	500M at DC 500V

-IEC

(V)	800
(III/3)(V)	800
(II/2)(KV)	8
(III/2)(KV)	8
(III/3)(KV)	8
(mm ²)	0.34
(mm ²)	4
(mm ²)	0.34
(mm ²)	2.5
(mm ²) , ,	0.34
(mm ²) , ,	2.5
(mm ²) , ,	0.34
(mm ²) , ,	2.5
2 (mm ²)	0.34
2 (mm ²)	2.5
2 (mm ²)	0.34
2 (mm ²)	2.5
(mm ²) 2 , ,	0.34
(mm ²) 2 , ,	1.5
2 (mm ²) , ,	0.5
2 (mm ²) , ,	1
	M2.5
Width)(mm) (Blade thickness x	0.4x2.5
Philips	PH0
(N.m)	0.4
(N.m)	0.4
(N.m)	0.5
	9~11
	TS-35

	YES
	NO

-UL

(UL/CUL Group B)(V)	600
(UL/CUL Group C)(V)	600
UL/CUL AWG	22
UL/CUL AWG	12
UL/CUL AWG	22
UL/CUL AWG	12

&

(YES or NO)	YES
가 (YES or NO)	YES
	120
	-40

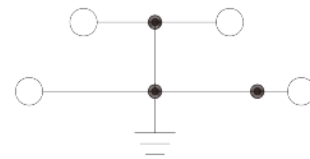
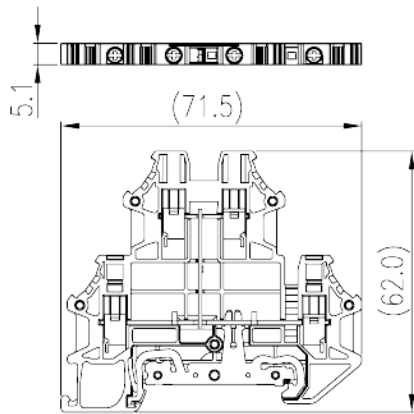



Delight Through Connections