

DPP2.5N-T

DIN

>

:2026-07-05

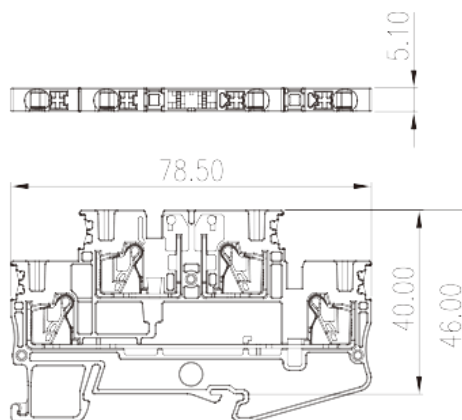
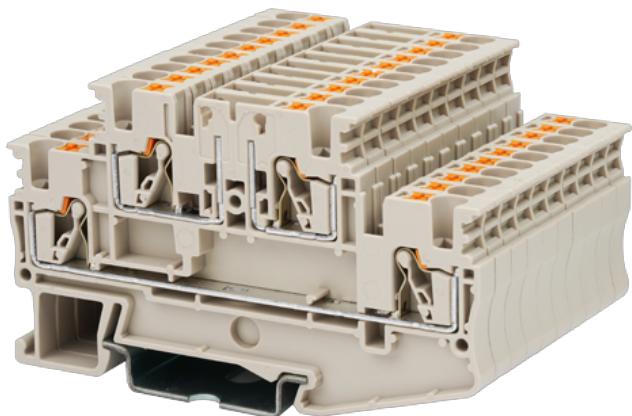

300V, 18A (Up) / 20A (Bottom), Beige (default)

	Bi-level Disconnect Terminal Block, Push-in Design
	Bi-level Disconnect Terminal Block
	Beige (default)
	Push-in Design
	Rail Mounting
(mm)	78.5
(mm)	5.1
(mm)	46/ 47.5 (TS-35N), 55 (TS-35/15N)
()	2P
	Double level
	4
	PA
	I
UL 94	V0
	500M at DC 500V

-IEC

(V)	400
(A)	20
(III/3)(V)	400
(III/3)(KV)	6
(mm ²)	0.14
(mm ²)	4
(mm ²)	0.14
(mm ²)	2.5
(mm ²) , ,	0.25
(mm ²) , ,	2.5
(mm ²) , ,	0.25
(mm ²) , ,	2.5
² (mm ²) , ,	0.5
² (mm ²) , ,	0.5
Width)(mm) (Blade thickness x	0.6X3.5
	10
	TS-35N、TS-35/15N
	YES
	NO

-UL

(UL/CUL Group B)(V)	300
(UL/CUL Group B)(A)	18 (Up) / 20 (Bottom)
(UL/CUL Group C)(V)	300
(UL/CUL Group C)(A)	18 (Up) / 20 (Bottom)
UL/CUL AWG	26
UL/CUL AWG	12
UL/CUL AWG	26
UL/CUL AWG	12

&

(YES or NO)	YES
가 (YES or NO)	YES
	120
	-40

UL

(Group B) (AWG)	26~12
(Group B) (V)	300
(Group B) (A)	18 (Up) / 20 (Bottom)
(Group C) (AWG)	26~12
(Group C) (V)	300
(Group C) (A)	18 (Up) / 20 (Bottom)

CUL

(Group B) (AWG)	26~12
(Group B) (V)	300
(Group B) (A)	18 (Up) / 20 (Bottom)
(Group C) (AWG)	26~12
(Group C) (V)	300
(Group C) (A)	18 (Up) / 20 (Bottom)

