

PM4H-16P

NEMA

>

:2025-06-16

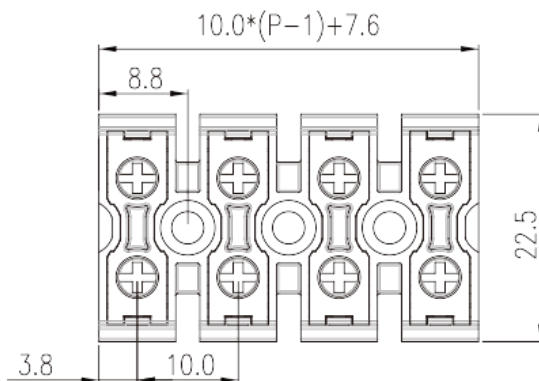

300V, 30A, Beige (default)

	Panel Mounting
	Panel Mounting
(mm)	10
	Refer to drawing
	Screw Connection
	With mounting flange
(mm)	$10 * (P - 1) + 7.6$
(mm)	22.5
(mm)	18.7
()	02P~16P
	Single level
	2
	PA
	I
UL 94	V0
	500M at DC 500V



		COPPER ALLOY
		Tin PLATED
-IEC		
(V)		630
(A)		32
(II/2)(V)		1000
(III/2)(V)		630
(III/3)(V)		630
(II/2)(KV)		6
(III/2)(KV)		6
(III/3)(KV)		6
(mm ²)		0.5
(mm ²)		4
(mm ²)		0.5
(mm ²)		4
(mm ²)	,	0.5
(mm ²)	,	4
(mm ²)	,	0.5
(mm ²)	,	4
2	(mm ²)	0.5
2	(mm ²)	2.5
2	(mm ²)	0.5
2	(mm ²)	2.5
(mm ²)	2 ,	0.5
(mm ²)	2 ,	2.5
(mm ²)	2 ,	0.5
(mm ²)	2 ,	2.5
		M3
Width)(mm)	(Blade thickness x	0.6x3.5

Philips		PH1
	(N.m)	0.5
	(N.m)	0.6
	(N.m)	0.5
		7~8

-UL

	(UL/CUL Group B)(V)	300
	(UL/CUL Group B)(A)	30
	(UL/CUL Group C)(V)	300
	(UL/CUL Group C)(A)	30
	(UL/CUL Group D)(V)	600
	(UL/CUL Group D)(A)	5
UL/CUL	AWG	22
UL/CUL	AWG	10
UL/CUL	AWG	22
UL/CUL	AWG	10

&

	(YES or NO)	YES
가	(YES or NO)	NO
		120
		-40

UL

	(Group B)(AWG)	22~10
	(Group B)(V)	300
	(Group B)(A)	30
	(Group C)(AWG)	22~10
	(Group C)(V)	300
	(Group C)(A)	30

CUL

	(Group B)(AWG)	22~10
	(Group B)(V)	300

(Group B)(A)	30
(Group C)(AWG)	22~10
(Group C)(V)	300
(Group C)(A)	30

