

DP2.5SGR-L24

DIN

>

:2026-07-05

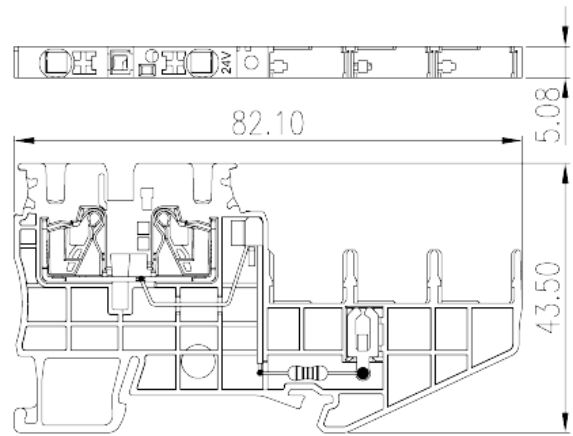
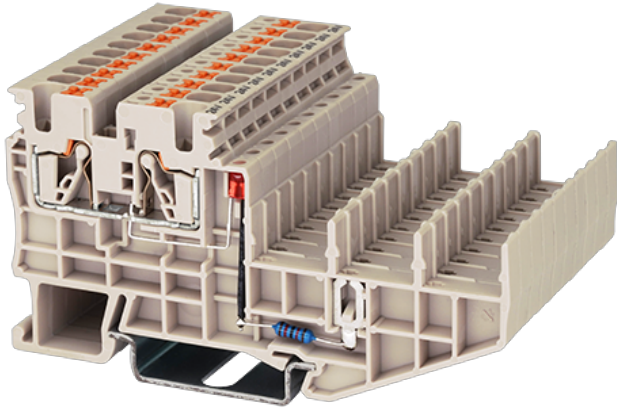

24V, 20A, Beige (default)

	Component terminal block, Push-in Design
	Component terminal block
	Refer to drawing
	Push-in Design
	Rail Mounting
(mm)	82.1
(mm)	5.08
(mm)	45 (TS-35N) / 52.5 (TS-35/15N)
()	1P
	Single level
	2
	PA
	I
UL 94	V0
	500M at DC 500V

-IEC

(V)	24
(A)	24
(III/3)(V)	24
(III/3)(KV)	4
(mm ²)	0.14
(mm ²)	4
(mm ²)	0.14
(mm ²)	2.5
(mm ²) , ,	0.25
(mm ²) , ,	2.5
(mm ²) , ,	0.25
(mm ²) , ,	2.5
² (mm ²) , ,	0.5
² (mm ²) , ,	0.5
Width)(mm) (Blade thickness x	0.6x3.5
	8~10
	TS-35N、TS-35/15N
	YES
	NO

-UL

(UL/CUL Group B)(V)	24
(UL/CUL Group B)(A)	20
(UL/CUL Group C)(V)	24
(UL/CUL Group C)(A)	20
UL/CUL AWG	26
UL/CUL AWG	12
UL/CUL AWG	26
UL/CUL AWG	12

&

(YES or NO)	YES
가 (YES or NO)	YES
	120
	-40

