

4DSDAN-XX

>

:2026-07-04

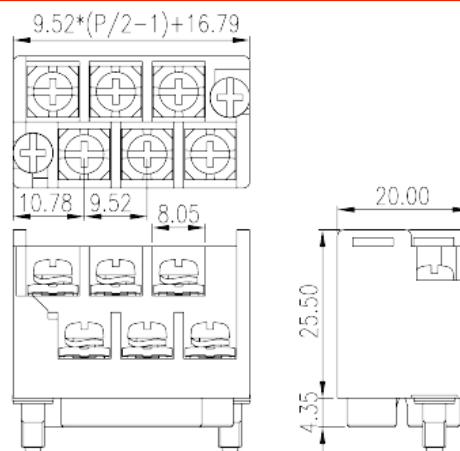

Pitch: 9.52mm, 300V, 15A

	Pluggable, Screw Connection
	Pluggable
(mm)	9.52
	Black (default)
	Screw connection
	With screw flange
(mm)	$9.52 \times (P/2 - 1) + 16.79$
(mm)	20
(mm)	29.85
()	08P~36P
	Bi-level
	8~36
	PBT
	IIIa
UL 94	V0
	1000M at DC 500V

		COPPER ALLOY
		Au PLATED
-IEC		
(V)		320
(A)		24
(II/2)(V)		320
(III/2)(V)		320
(III/3)(V)		200
(II/2)(KV)		4
(III/2)(KV)		4
(III/3)(KV)		4
(mm ²)		0.75
(mm ²)		2.5
(mm ²)		0.75
(mm ²)		2.5
2	(mm ²)	0.75
2	(mm ²)	1.5
2	(mm ²)	0.75
2	(mm ²)	1.5
		M3.5
Width)(mm)	(Blade thickness x	1x5.5
Philips		PH2
(N.m)		0.8
(N.m)		1
(N.m)		0.5
		8~9
-UL		
(UL/CUL Group B)(V)		300
(UL/CUL Group B)(A)		15
(UL/CUL Group D)(V)		300
(UL/CUL Group D)(A)		10
UL/CUL	AWG	18



UL/CUL	AWG	14
UL/CUL	AWG	18
UL/CUL	AWG	14

&

(YES or NO)	YES
	120
	-40

UL

(Group B)(AWG)	18~14
(Group B)(V)	300
(Group B)(A)	15
(Group D)(AWG)	18~14
(Group D)(V)	300
(Group D)(A)	10

CUL

(Group B)(AWG)	18~14
(Group B)(V)	300
(Group B)(A)	15
(Group D)(AWG)	18~14
(Group D)(V)	300
(Group D)(A)	10

--	--

