

# DT-69-H53W-XX

>

:2026-07-05 :1.1

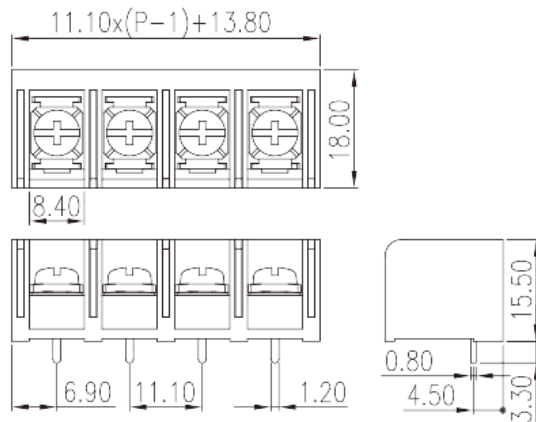

Pitch: 11.10mm , #6-32, 600V, 20/45A

	Barrier terminal blocks , Screw connection
	Single Row
(mm)	11.10
	Black(default)
	Screw connection
	Without
( x ) (mm)	0.8X1.2
PCB (mm)	1.5~1.6
	Single Row
	PBT
	IIIa
UL 94	V0
	Copper Alloy
	Tinned

-IEC



(A)		32
(II/2)(V)		800
(III/2)(V)		800
(III/3)(V)		500
(II/2)(KV)		8
(III/2)(KV)		8
(III/3)(KV)		8
(mm <sup>2</sup> )		0.34
(mm <sup>2</sup> )		4
(mm <sup>2</sup> )		0.34
(mm <sup>2</sup> )		4
2	(mm <sup>2</sup> )	2.5
2	(mm <sup>2</sup> )	2.5
		#6-32
Width)(mm)	(Blade thickness x	1.0x5.5
Philips		PH2
(N.m)		1
(N.m)		0.8
(N.m)		1
		7~8

**-UL**

(UL/CUL Group B)(V)		600
(UL/CUL Group B)(A)		20 Str /45 Sol
(UL/CUL Group C)(V)		600
(UL/CUL Group C)(A)		20 Str/45 Sol
UL/CUL	AWG	22/10
UL/CUL	AWG	12/8
UL/CUL	AWG	22/10
UL/CUL	AWG	12/8

**&**

(YES or NO)		YES
		130

-40

**UL**

(Group B) (AWG)	22~8
(Group B) (V)	600
(Group B) (A)	20 Str /45 Sol
(Group C) (AWG)	22~8
(Group C) (V)	600
(Group C) (A)	20 Str/45 Sol

**CUL**

(Group B) (AWG)	22~8
(Group B) (V)	600
(Group B) (A)	20 Str /45 Sol
(Group C) (AWG)	22~8
(Group C) (V)	600
(Group C) (A)	20 Str/45 Sol

**VDE**

(mm <sup>2</sup> )	0.34~4
(A)	32

