

4DSDAC-XX

>

:2026-07-04 :1.1

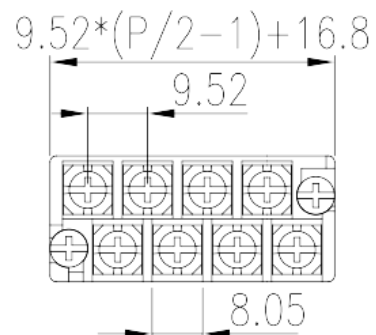

Pitch : 9.50 mm , M3.5 , 300V , 15A

	Barrier terminal blocks , Screw connection
	Pluggable terminal blocks
(mm)	9.50
	Black(default)
	Screw connection
	With screw flange
	Double level
	PBT
	IIIa
UL 94	V0
	Copper Alloy
	Gold plated
-IEC	
(V)	250
(A)	24

(II/2)(V)		250
(III/2)(V)		250
(III/3)(V)		160
(II/2)(KV)		4
(III/2)(KV)		4
(III/3)(KV)		4
(mm ²)		0.75
(mm ²)		2.5
(mm ²)		0.75
(mm ²)		2.5
2	(mm ²)	1.5
2	(mm ²)	1.5
		M3.5
Width)(mm)	(Blade thickness x	0.8x4.0
Philips		PH2
(N.m)		1.4
(N.m)		0.8
(N.m)		1.4
		8~9

-UL

(UL/CUL Group B)(V)		300
(UL/CUL Group B)(A)		15
UL/CUL	AWG	18
UL/CUL	AWG	14
UL/CUL	AWG	18
UL/CUL	AWG	14

&

(YES or NO)		YES
		130
		-40

UL

(Group B)(AWG)	18~14
(Group B)(V)	300
(Group B)(A)	15

CUL

(Group B)(AWG)	18~14
(Group B)(V)	300
(Group B)(A)	15

VDE

(mm ²)	0.75~2.5
(V)	250
(A)	24

