

# P-851

>

:2026-07-04

:1.2

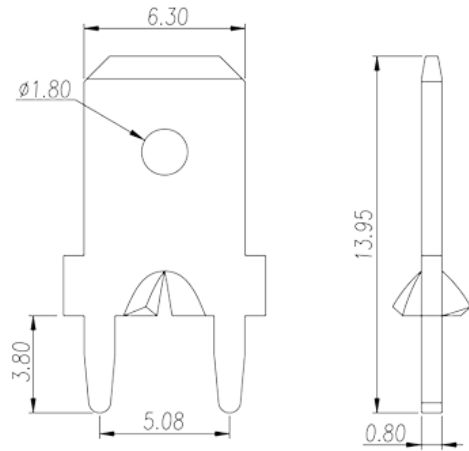
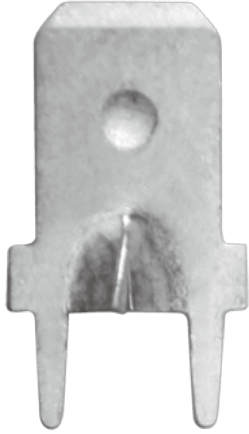

Pitch : 5.08mm, 0.8x1.2mm, 30A

	Barrier terminal blocks, Quick terminal blocks
	Quick terminal blocks
(mm)	5.08
( x ) (mm)	0.8x1.2
	COPPER ALLOY
	Tin PLATED
<b>-IEC</b>	
(A)	30

