

P-810

>

:2026-07-04

:1.2

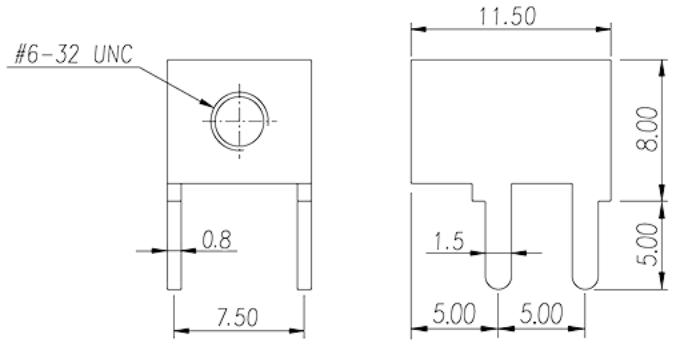
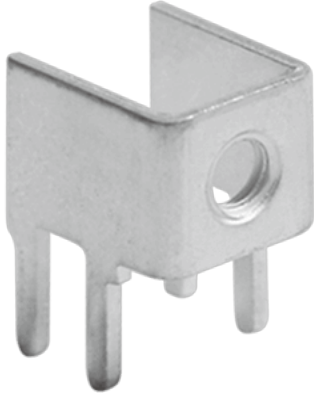

Pin size: 0.8x1.5mm, 80A

	Barrier terminal blocks, Quick terminal blocks
	Quick terminal blocks
(x) (mm)	0.8x1.5
	COPPER ALLOY
	Tin PLATED
-IEC	
(A)	80
	#6-32

