

# P-820W

>

:2026-07-04 :1.2

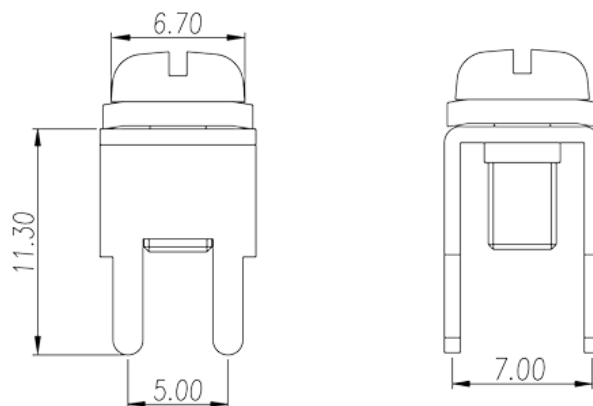
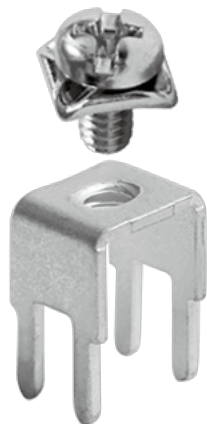

Pitch : 5.00 / 7.00 mm, 0.8x1.5mm, 50A

	Barrier terminal blocks, Quick terminal blocks
	Quick terminal blocks
(mm)	5.00 / 7.00
(    x    ) (mm)	0.8x1.5

	COPPER ALLOY
	Tin PLATED

## -IEC

(A)	50
	#6-32
Width)(mm)                      (Blade thickness x	0.8x4.0
Philips	PH2
(N.m)	0.8
(N.m)	1

