

P-840W

>

:2026-07-04 :1.2

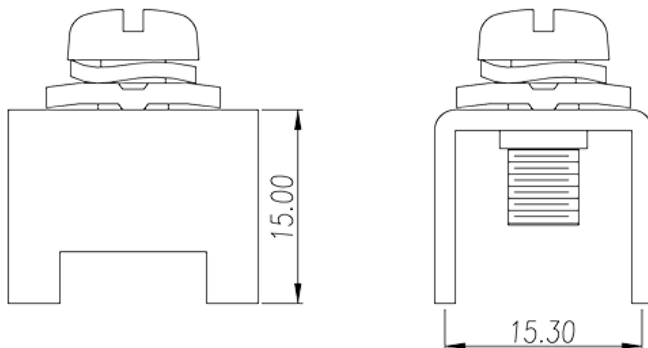

Pitch : 15.30 / 15.40 mm, 1.6x4.0mm, 150A

	Barrier terminal blocks, Quick terminal blocks
	Quick terminal blocks
(mm)	15.30 / 15.40
(x) (mm)	1.6x4.0

	COPPER ALLOY
	Tin PLATED

-IEC

(A)	150
	M6
Width)(mm) (Blade thickness x	1.0x5.5
Philips	PH3
(N.m)	2.5
(N.m)	3

