

# 2EHDRS-XXP

PCB >

:2026-07-05 :1.1

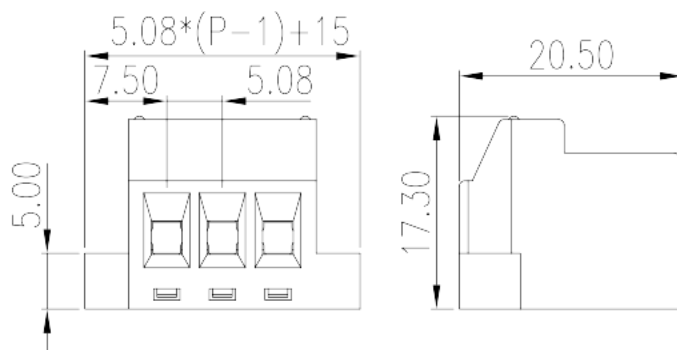

Pitch: 5.08 mm, 300V, 12/15A

	Special type terminal blocks, Screw connection
	Special type terminal blocks
(mm)	5.08
	Green (default)
	Screw connection
	With mounting flange
(mm)	$5.08 * (P - 1) + 15$
(mm)	20.50
(mm)	17.3
( )	02~20P
	PA
	I
UL 94	V0
	COPPER ALLOY
	Tin PLATED

**-IEC**

(V)	630
(A)	18
(II/2)(V)	600
(III/2)(V)	320
(III/3)(V)	250
(II/2)(KV)	4
(III/2)(KV)	4
(III/3)(KV)	4
(mm <sup>2</sup> )	0.5
(mm <sup>2</sup> )	2.5
(mm <sup>2</sup> )	0.5
(mm <sup>2</sup> )	2.5
(mm <sup>2</sup> )	0.25
(mm <sup>2</sup> )	2.5
(mm <sup>2</sup> )	0.25
(mm <sup>2</sup> )	1.5
2 (mm <sup>2</sup> )	1.5
2 (mm <sup>2</sup> )	1.5
(mm <sup>2</sup> ) <sup>2</sup>	0.25
(mm <sup>2</sup> ) <sup>2</sup>	0.75
(mm <sup>2</sup> ) <sup>2</sup>	0.5
(mm <sup>2</sup> ) <sup>2</sup>	1.5
	M2.5
Width)(mm) (Blade thickness x	0.6x3.5
Philips	PH1
(N.m)	0.75
	7~8

**-UL**

(UL/CUL Group B)(V)		300
(UL/CUL Group B)(A)		12/15
UL/CUL	AWG	24/28
UL/CUL	AWG	12/16
UL/CUL	AWG	24/28
UL/CUL	AWG	12/16

&amp;

(YES or NO)		YES
가 (YES or NO)		YES
		115
		-40

## UL

(Group B)(AWG)		28~12
(Group B)(V)		300
(Group B)(A)		12/15

## CUL

(Group B)(AWG)		28~12
(Group B)(V)		300
(Group B)(A)		12/15

