

# PPAC-95M

PCB >

:2026-07-04 :1.2

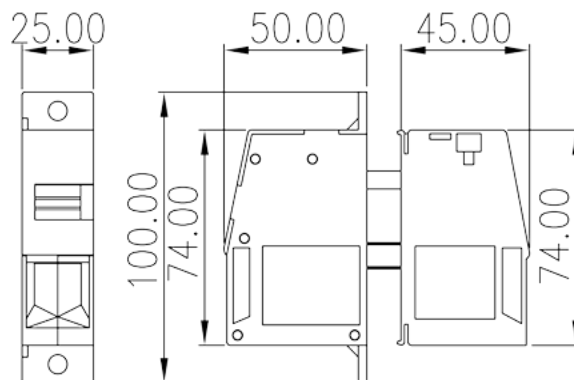

M8, 600V, 230A

	Panel Feed-Through, Screw Connection
	Panel Feed-Through
	Grey (default)
	Screw connection
	Without
(mm)	25
(mm)	50+45
(mm)	100
( )	1P
	PA
	I
UL 94	V0
	500M at DC 500V
	COPPER ALLOY
	Tin PLATED

**-IEC**

(V)	630V (5.0 ~ 6.0mm mounting plate), 800V (2.5 ~ 5.0mm mounting plate), 1000V (1.0 ~ 2.5mm mounting plate)
(A)	232
(III/3)(V)	630V (5.0 ~ 6.0mm mounting plate), 800V (2.5 ~ 5.0mm mounting plate), 1000V (1.0 ~ 2.5mm mounting plate)
(III/3)(KV)	8
(mm <sup>2</sup> )	25
(mm <sup>2</sup> )	95
(mm <sup>2</sup> )	25
(mm <sup>2</sup> )	95
(mm <sup>2</sup> ) , ,	25
(mm <sup>2</sup> ) , ,	95
(mm <sup>2</sup> ) , ,	25
(mm <sup>2</sup> ) , ,	95
2 (mm <sup>2</sup> )	25
2 (mm <sup>2</sup> )	35
2 (mm <sup>2</sup> )	25
2 (mm <sup>2</sup> )	35
(mm <sup>2</sup> ) <sup>2</sup> , ,	16
(mm <sup>2</sup> ) <sup>2</sup> , ,	35
	M8
Philips	#6
(N.m)	15
	26~27

**-UL**

(UL/CUL Group B)(V)	600
(UL/CUL Group B)(A)	230
(UL/CUL Group C)(V)	600
(UL/CUL Group C)(A)	230



UL/CUL	AWG	4
UL/CUL	AWG	4/0
UL/CUL	AWG	4
UL/CUL	AWG	4/0

&

(YES or NO)	YES
가 (YES or NO)	YES
	120
	-40

### UL

(Group B)(AWG)	4~4/0
(Group B)(V)	600
(Group B)(A)	230
(Group C)(AWG)	4~4/0
(Group C)(V)	600
(Group C)(A)	230

### CUL

(Group B)(AWG)	4~4/0
(Group B)(V)	600
(Group B)(A)	230
(Group C)(AWG)	4~4/0
(Group C)(V)	600
(Group C)(A)	230

--	--

