

0032-0105

>

:2026-07-04 :1.1

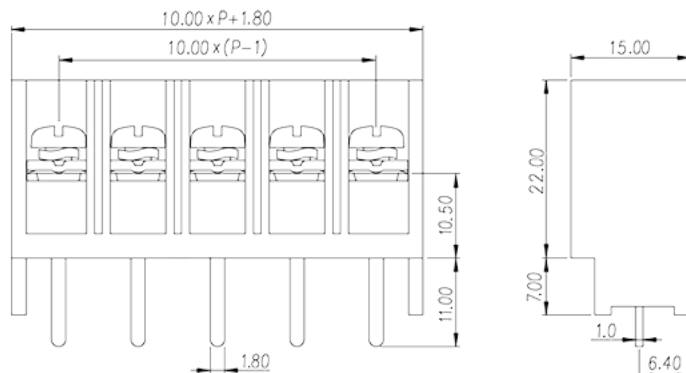
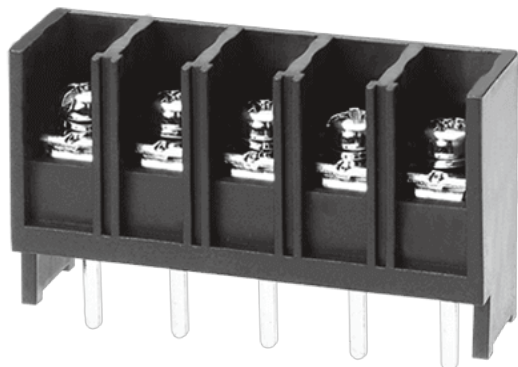

Pitch: 10.00mm, M4, 300V, 30 Str / 25 Sol

	Barrier terminal blocks, Screw connection
	Single Row
(mm)	10
	Black (default)
	Screw connection
	Without
	Wave Soldering
(mm)	51.8
(mm)	15
(mm)	29
() x () (mm)	1.0x1.8
PCB (mm)	2.5
()	08P
	Single Row
	PBT
	IIIa

UL 94	V0
	1000M at DC 500V
	COPPER ALLOY
	Tin PLATED

-IEC

(V)	1000
(A)	32
(II/2)(V)	1000
(III/2)(V)	1000
(III/3)(V)	500
(II/2)(KV)	8
(III/2)(KV)	8
(III/3)(KV)	8
(mm ²)	0.75
(mm ²)	4
(mm ²)	0.75
(mm ²)	4
2 (mm ²)	2.5
2 (mm ²)	2.5
	M4
Width)(mm) (Blade thickness x	1.0x5.5
Philips	PH2
(N.m)	1.6
(N.m)	1.2
(N.m)	1.6
	10~11

-UL

(UL/CUL Group B)(V)	300
(UL/CUL Group B)(A)	30 Str / 25 Sol
(UL/CUL Group C)(V)	300
(UL/CUL Group C)(A)	30 Str / 25 Sol
(UL/CUL Group D)(V)	600



(UL/CUL Group D)(A)		5
UL/CUL	AWG	18
UL/CUL	AWG	10
UL/CUL	AWG	18
UL/CUL	AWG	10

&

(YES or NO)		YES
		120
		-40

UL

(Group B)(AWG)		18~10
(Group B)(V)		300
(Group B)(A)		30 Str / 25 Sol
(Group C)(AWG)		18~10
(Group C)(V)		300
(Group C)(A)		30 Str / 25 Sol
(Group D)(AWG)		18~10
(Group D)(V)		600
(Group D)(A)		5

CUL

(Group B)(AWG)		18~10
(Group B)(V)		300
(Group B)(A)		30 Str / 25 Sol
(Group C)(AWG)		18~10
(Group C)(V)		300
(Group C)(A)		30 Str / 25 Sol
(Group D)(AWG)		18~10
(Group D)(V)		600
(Group D)(A)		5

