

ECH880RT-XXP

PCB > PCB -

:2026-07-05 :V1

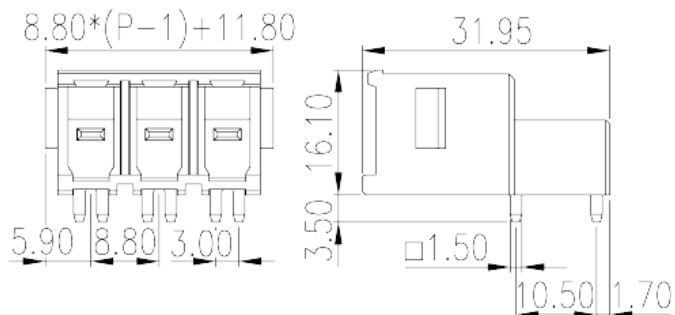
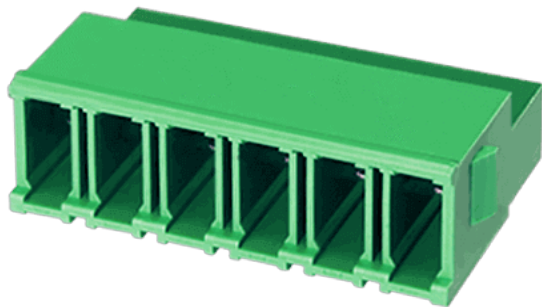

Pitch: 8.80 mm , 600V, 65A

	PCB connector Socket, Wave soldering
	PCB connector Socket
(mm)	8.80
	Green(default)
	With lock flange
	Wave soldering
(mm)	$8.80 \times (P-1) + 8.50$
(mm)	31.95
(mm)	15.6
() x () (mm)	1.5x1.5
PCB (mm)	2.5~2.6
()	02P~12P
	Single level
	PA
	I
UL 94	V0



	500M at DC 500V
	COPPER ALLOY
	Tin PLATED

-IEC

(V)	1000
(A)	57
(II/2)(V)	1000
(III/2)(V)	1000
(III/3)(V)	1000
(II/2)(KV)	8
(III/2)(KV)	8
(III/3)(KV)	8

-UL

(UL/CUL Group B)(V)	600
(UL/CUL Group B)(A)	65
(UL/CUL Group C)(V)	600
(UL/CUL Group C)(A)	65

&

가 (YES or NO)	YES
	115
	-40

UL

(Group B)(V)	600
(Group B)(A)	65
(Group C)(V)	600
(Group C)(A)	65

CUL

(Group B)(V)	600
(Group B)(A)	65
(Group C)(V)	600

(Group C) (A)

65

