

P-820W

柵板式端子台 > 獨立端子

下載日期:2026-04-15版次:1.2

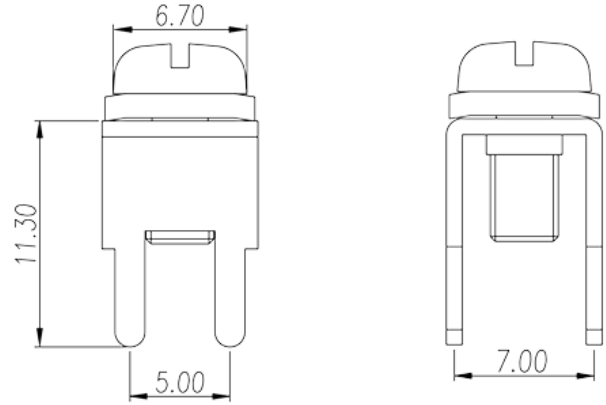

目錄僅供參考，實際規格仍依照產品工程圖面為準

產品介紹

Pitch : 5.00 / 7.00 mm, 0.8x1.5mm, 50A

一般資訊

產品概述	Barrier terminal blocks, Quick terminal blocks
產品類型	Quick terminal blocks
產品間距 (mm)	5.00 / 7.00
出腳尺寸 (厚度___ x 寬度___mm)	0.8x1.5

材料資訊

導體材料	COPPER ALLOY
導體表面鍍層	Tin PLATED

連接數據-IEC

額定電流 (A)	50
螺紋規格	#6-32
一字螺絲刀規格 (刃厚_x刃寬_)(mm)	0.8x4.0
螺絲刀規格	PH2
建議最小扭矩 (N.m)	0.8
建議最大扭矩 (N.m)	1

圖面

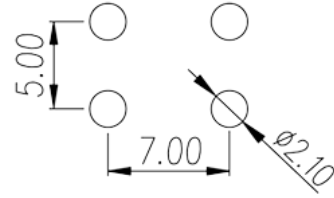
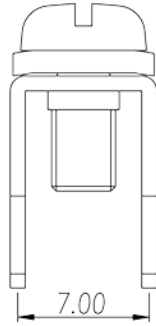
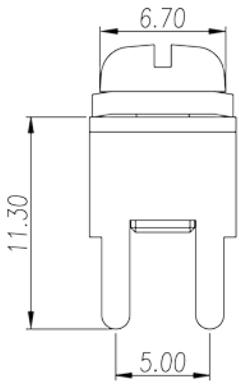

認證

